

The Cobot torch support bracket is designed to work with air- or liquid-cooled, external-beam, MIG-MAG welding torches by Binzel®. Setting up the torch is quick, simple and tool-less.

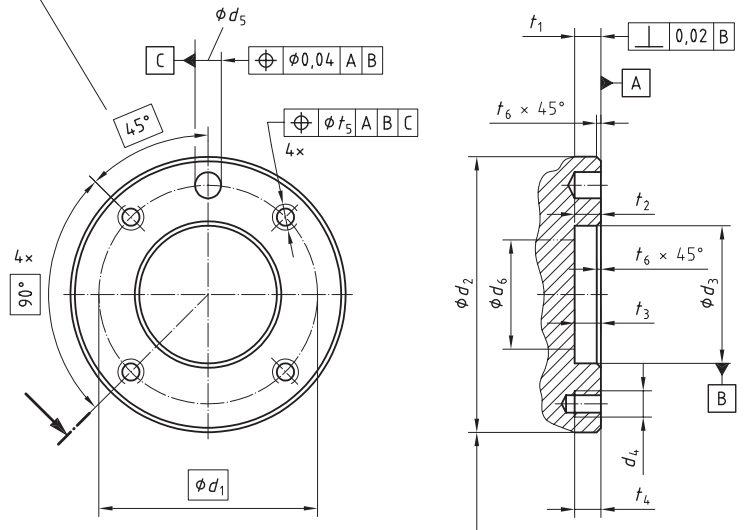

Compatible with most Cobot arms currently available on the market:

- Universal Robot®
- Doosan®
- TECHMAN®
- HANWHA®
- JAKA®
- OMRON®



**MIG-MAG compatible torches**

MIG/MAG GRIP 350 A steel - 4 m - Air Original equipment: Ø 1.2 (steel)	040946
MIG/MAG GRIP 500 A steel - 4 m - Liquid Original equipment: Ø 1.2 (steel)	041004

**Dimensions in mm (ISO 9409-1:2004)**

d1	d2	d3	d4	d5	d6	t1	t2	t3	t4	t5	t6
	h8	H7		H7		min.	min.	min.			min
50	63	31,5	M6	6	-	6	6	6	-	0,2	1